

4 Finger Soft Gripper

Cone Angle 30°, 60° & 90°

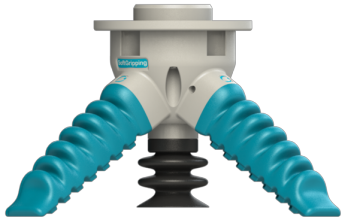

Cone Angle 30°

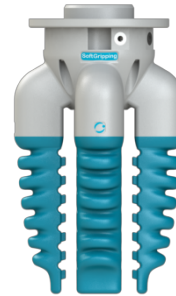

Cone Angle 60°



Cone Angle 90°

Typical Gripping Objects

- Cylindrical or Cubic
 - Diameter 55 mm – 140 mm
 - Weight <400 g
- Cylindrical or Cubic
 - Diameter 15 mm – 115 mm
 - Weight <400 g
- Cylindrical or Cubic
 - Diameter 5 mm – 40 mm
 - Weight <400 g

Finger Material	Silicone
Operating Pressure	- 0.5 to 1.0 bar
Grip Force per Finger	3,5 N
Durability	> 1 Mio. Cycles @1.0 bar, 0.5 Hz

Elements of the Soft-Gripping Construction Kit

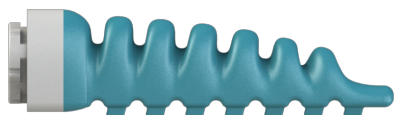

4 x Finger Shore A60



1 x 4 Finger Gripper Base

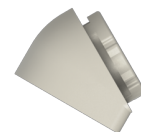

4 x 60° angle adapter



1 x Connector ISO 9409-1-50-4-M6



1 x Vacuum Suction Cup
(optional accessory)

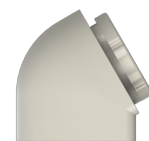

4 x 90° angle adapter

4 Finger Soft Gripper

30°, 60° & 90° Cone Angle

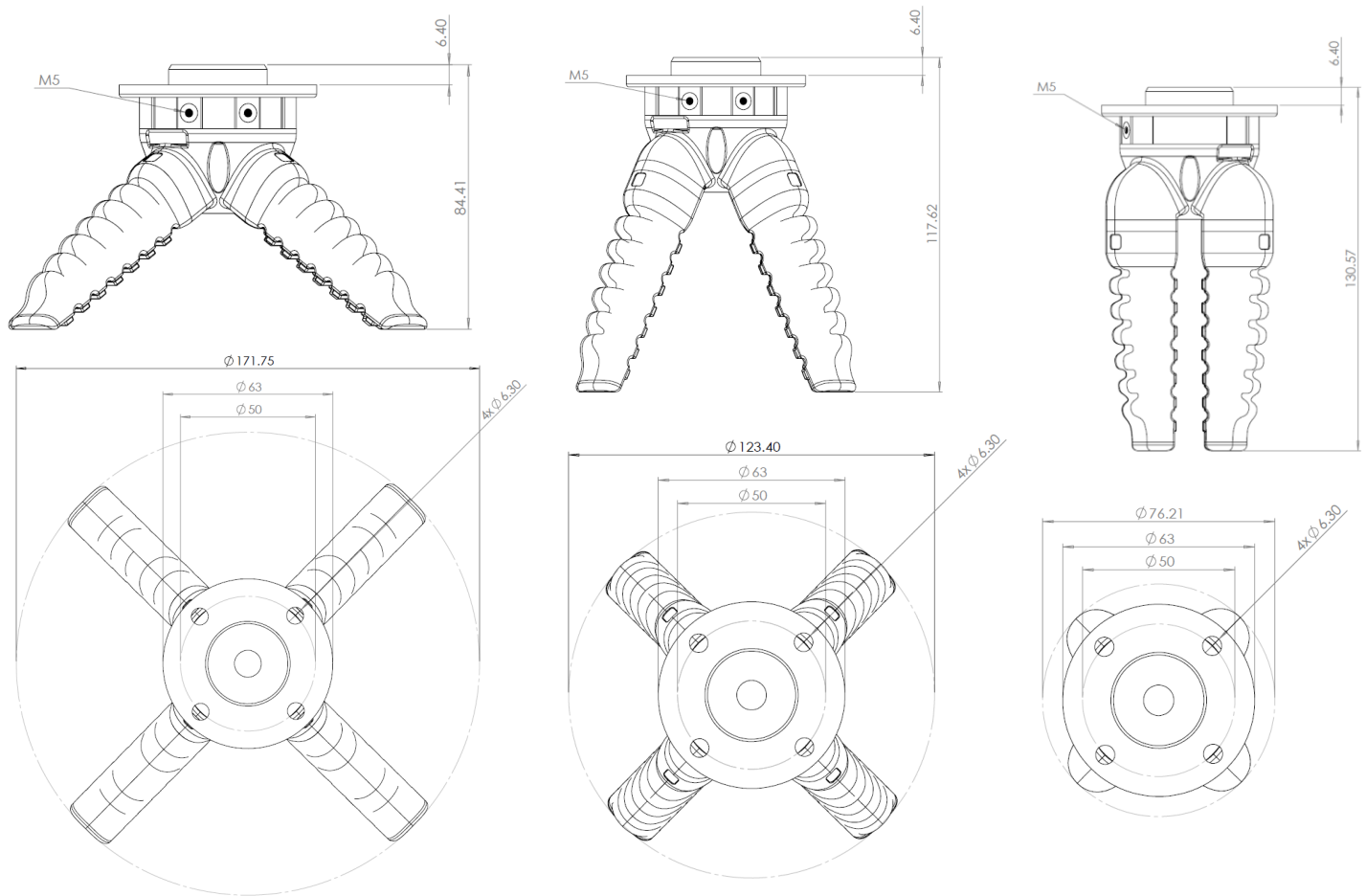

Connector ¹	ISO 9409-1-50-4-M6
Air Pressure Connection	2 x M5
Total Height 30° 60° 90°	84,41 117,62 130,57 mm
Total Diameter 30° 60° 90°	171,75 123,40 76,21 mm
Mass	228,90 g

¹ Suitable for UR-Robots. Other connectors available.